

DKG-109J AUTOMATIC MAINS FAILURE UNIT WITH J1939 INTERFACE

DESCRIPTION

The DKG-109J is a comprehensive AMF unit for a single genset standby or dual genset mutual standby operations.

The unit can connect to ECU controlled electronic engines through its standard J1939 CANBUS port providing engine control, protection and instrumentation without extra senders. The ECU alarms are displayed in text.

In AUTOMATIC position, DKG-109 monitors mains phase voltages and controls the automatic starting, stopping and load transfer of the generating set in case of a mains failure and once the generator is running, it monitors internal protections and external fault inputs. If a fault condition occurs, the unit shuts down the engine automatically and indicates the failure source with the corresponding red led lamp and text.

The operation of the unit is controlled with front panel pushbuttons. The AUTO, OFF, RUN pushbuttons select the operating mode. Other buttons select the display parameter scroll, alarm mute and lamp test functions.

The DKG-109J provides a comprehensive set of digitally adjustable timers, threshold levels, input and output configurations, operating sequences and engine types. All programs may be modified via front panel pushbuttons, and do not require an external unit.

The fault conditions are considered in 3 categories as Warnings, Loaddumps and Shutdown Alarms. Measured values have separate programmable limits for warning and shutdown conditions. The unit is able to send SMS messages in fault conditions.

Last 200 faults are stored in the event log file. The event log includes not only the date-time information, but also a comprehensive list of measured genset parameters at the time that the fault has occurred.

The service request indicator lamp turns on at the expiration of either engine hours or time limits.

It is possible to monitor and control the operation of the system locally or remotely with the WINDOWS based RAINBOW program.

The unit supports MODBUS protocol enabling communication with PLCs and building management systems. The MODBUS protocol is also supported through GSM and PSTN modems.

The unit offers triple language support. Default languages are English-Turkish and Chinese.

MEASUREMENTS

Generator Volts: L1-N
 Generator Amps: L1
 Generator KW: L1
 Generator pf: L1
 Generator Frequency
 Engine rpm
 Mains Volts: L1-N, L2-N, L3-N
 Mains Volts: L1-L2, L2-L3, L3-L1
 Mains Frequency
 Battery Voltage
 Engine Coolant Temperature
 Engine Oil Pressure
 Fuel Level

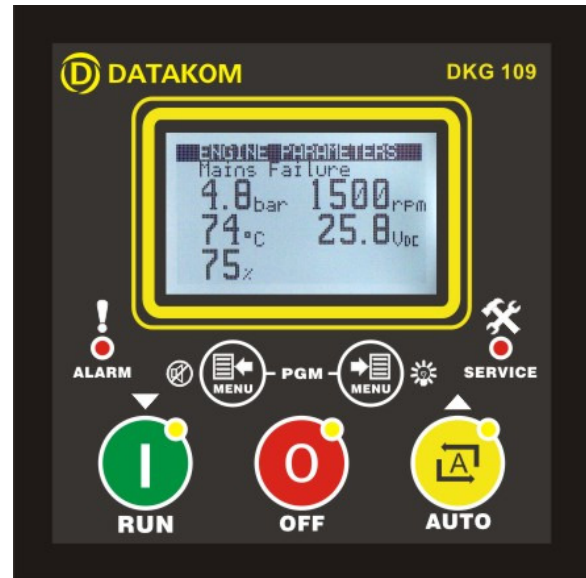

FEATURES

- True RMS measurements**
- Automatic mains failure**
- ECU control and monitoring through J1939 CAN**
- J1939 ECU warnings displayed as text**
- Various engine brands and models available**
- Gas engine support**
- Engine idle speed control**
- Generator protection**
- Built in alarms and warnings**
- Remote Start operation available**
- Dual genset mutual standby operation**
- Load shedding, dummy load**
- Periodic maintenance request monitoring**
- Event logging with measurements**
- Statistical counters**
- Field adjustable parameters**
- Logic level serial port**
- Firmware downloadable from serial port**
- Free MS-Windows Remote monitoring SW:**
 - monitoring and control
 - download of parameters
 - upload of parameters
- GSM SMS message sending on fault**
- MODBUS communications**
- Graphic LCD display (128x64 pixels)**
- Triple language support**
- Customer logo display capability**
- Protected semiconductor digital outputs**
- Configurable analogue inputs: 3**
- Configurable digital inputs: 5**
- Configurable relay outputs: 2**
- Total relay outputs: 6**
- Survives cranking dropouts**
- Sealed front panel**
- Plug-in connection system for easy replacement**

STATISTICS

Following incremental counters provide statistics about past performance of the generating set:

Engine Hours Run
Total KW-h
Engine Hours to Service
Time to Service
Number of Engine Cranks
Number of Genset Runs

EVENT LOGGING

The DKG-109J records last 200 events with a total of 18 measured parameters. Recorded events are:

-shutdown alarms, load dumps and warnings
-periodic records

DIGITAL INPUTS

The unit has 5 configurable digital inputs. Each input has following programmable parameters:

-alarm type: shutdown / load_dump / warning / no alarm
-alarm polling: on engine running / always / on mains OK
-latching / non-latching operation,
-contact type: NO / NC
-switching: BAT+ / BAT-

ANALOG INPUTS

Engine analog inputs are provided for coolant temperature, oil pressure and fuel level. Analog inputs connect to resistive sender units to provide precise and adjustable protection. The inputs have programmable sensor characteristics so that they are suitable for any type and any brand of sensors.

DIGITAL OUTPUTS

The unit provides 6 digital outputs and 2 of them have programmable functions, selectable from a list. Any function or alarm condition may be output as a relay output.

TELEMETRY AND REMOTE PROGRAMMING

The unit provides the user with large telemetry facilities via its logic level serial port, connecting either to a PC or PLC (external adapter required). It supports both RAINBOW and MODBUS communication protocols.

The PC program is used for below purposes:

-monitoring and control
-parameter upload/download
-diagnostics and analysis

The MODBUS interface allows the unit to be integrated in building management systems.

TECHNICAL SPECIFICATIONS

Alternator voltage: 0 to 300 V-AC (Ph-N)

Alternator frequency: 0-100 Hz.

Mains voltage: 0 to 300 V-AC (Ph-N)

Mains frequency: 0-100 Hz.

DC Supply Range: 9.0 to 30.0 V-DC

Cranking dropouts: survives 0 V for 100ms.

Typical Standby Current: 100 mA-DC

Maximum Operating Current: 200 mA-DC (outputs open)

Generator/Mains Contactor Relay Outputs: 16 A / 250V

DC Outputs: 1A @ 28V

Charge excitation current: min 150mA @ 10 to 30 V-DC

Current inputs: from CTs, .../5A. Max load 0.7VA per phase.

Analog input range: 0-5000 ohms.

Serial port: Logic levels, 9600 bauds, no parity, 1 bit stop

Operating temp.: -20°C (-4°F) to 70 °C (158°F).

Storage temp.: -40°C (-40°F) to 80 °C (176°F).

Maximum humidity: 95% non-condensing.

Dimensions: 96 x 96 x 53 mm (WxHxD)

Panel Cut-out Dimensions: 92x92 mm minimum.

Weight: 200 g (approx.)

Case Material: High Temperature ABS/PC (UL94-V0)

IP Protection: IP65 from front panel, IP30 from the rear

Conformity (EU directives)

-2006/95/EC (low voltage)

-2004/108/EC (electro-magnetic compatibility)

Norms of reference:

EN 61010 (safety requirements)

EN 61326 (EMC requirements)

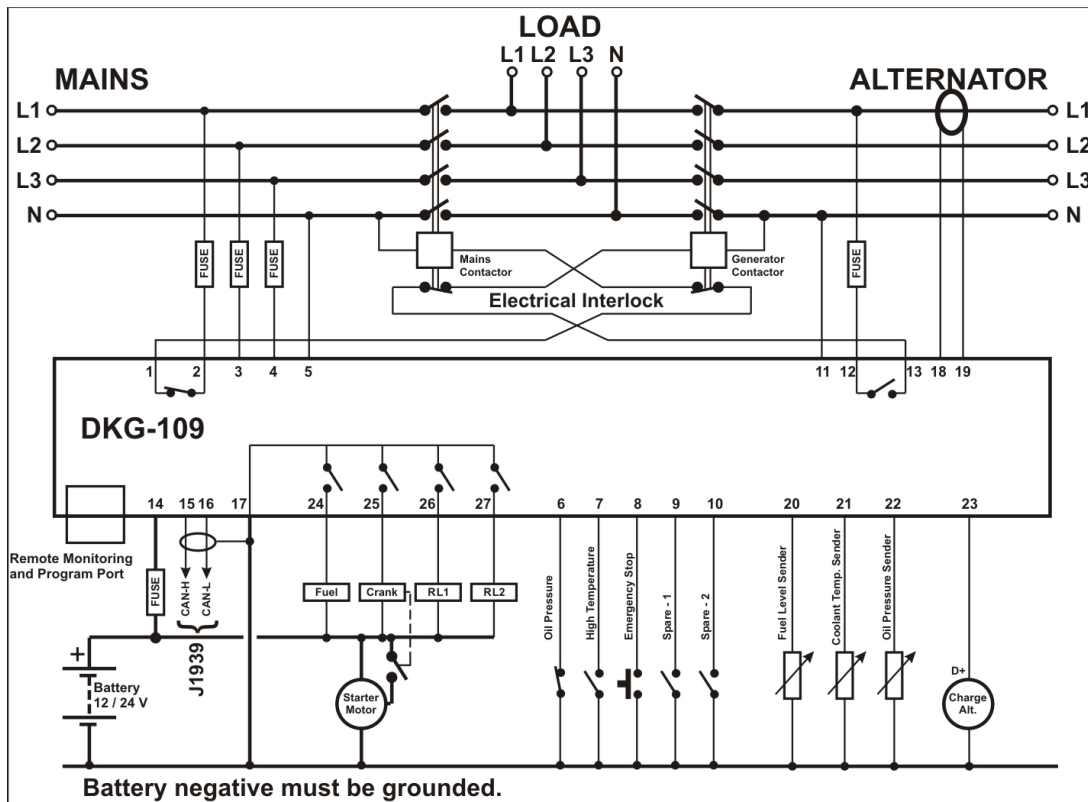

DATAKOM Electronics Ltd.

Tel : +90-216-466 84 60

Fax : +90-216-364 65 65

<http://www.datakom.com.tr>

e-mail : datakom@datakom.com.tr