

## DKG-151 MANUAL START UNIT INSTALLATION AND OPERATING INSTRUCTIONS

### DESCRIPTION

The model DKG-151 is a microprocessor controlled unit used to start and stop the genset manually using the key switch and pushbuttons on the front panel.

When the engine is running, the unit monitors fault conditions and shuts-down the engine automatically in the occurrence of an alarm. The alarms are identified by a group of LEDs displaying only the first occurring one.

The unit has jumper selectable options for 50/60Hz nominal frequency and the auxiliary relay output function. The selection is made by the position of a single jumper situated at the left side panel of the unit.

#### If the jumper is placed between:

- A & B** : 50 Hz nominal, AUX is Preheat output
- B & C** : 60 Hz nominal, AUX is Preheat output
- C & D** : 60 Hz nominal, AUX is Stop output
- D & A** : 50 Hz nominal, AUX is Stop output

In the **OFF** position, the DC supply is removed from the module, thus zero power consumption is achieved.

### OPERATION

The unit powers up when the **RUN** position on the front panel is selected. If required, the **PREHEAT/STOP** (⌘) button may be depressed as long as needed. This will activate the **AUXILIARY** relay output and the related front panel led marked (⌘).

The engine is started using the pushbutton marked **CRANK** (I). This will also energize the fuel solenoid relay. Once the engine is running, the switch should be released. However the internal logic inhibits cranking when the engine fires up.

The alarm checking is only enabled after the **protection hold-off timer** is expired. This timer resets to 12 seconds if:

- the unit is powered up,
- or **CRANK** (I) button is pressed,
- or **PREHEAT/STOP** (⌘) button is pressed,
- or the engine gets running.

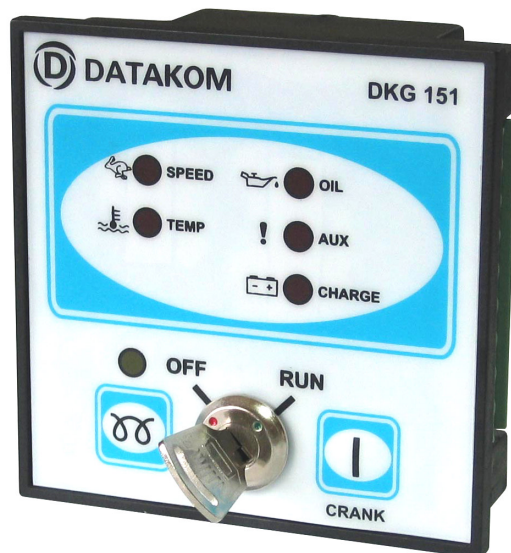

The occurrence of below fault signals (which are close on fault) will cause the engine to be stopped immediately:

- Overspeed,
- Underspeed,
- High engine temperature,
- Low oil pressure,
- Auxiliary shutdown.

If a fault condition occurs, the **FUEL** solenoid will be deenergized. If the auxiliary relay output is set to **Stop** option, the **AUXILIARY** relay output will be energized during stop timeout and the led associated with this condition will turn on. To reset the fault condition, turn the switch to the **OFF** position for a few seconds.

The **Charge Fail** input is treated as a warning only and do not cause the engine to stop. The input monitors the **D+** terminal of the charge alternator.

#### To shut-down the engine manually:

- if the **AUX** output is set to **Stop** option, press the **PREHEAT/STOP** (⌘) button until the engine comes to rest. Then select the **OFF** position on the switch.
- else select the **OFF** position on the switch.

## TYPICAL CONNECTION DIAGRAM

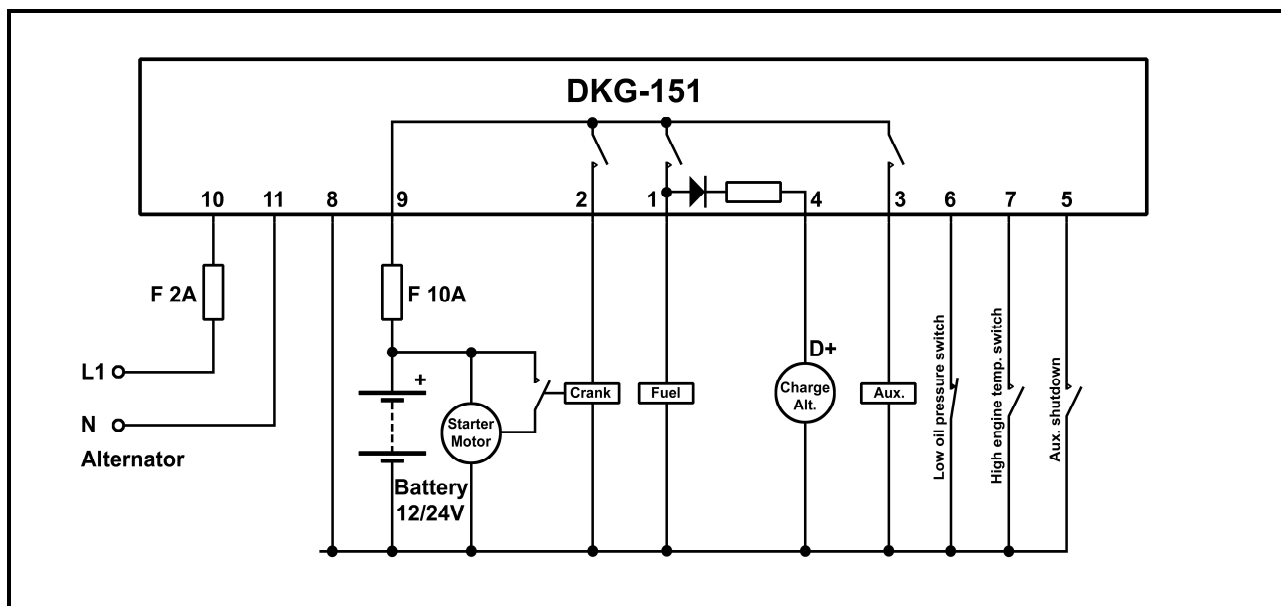

### INPUTS

**DC SUPPLY:** 12 or 24 volts DC, (+) and (-) terminals.

**L1:** Generator phase voltage.

**NEUTRAL:** Generator neutral terminal.

**HIGH TEMP SWITCH:** Negative closing switch input.

**LOW OIL PRESSURE:** Negative closing switch input.

**AUX:** Spare fault input. A negative supply connection to this input will cause the engine immediately stopped and an alarm given (independent of the protection hold-off timer).

**CHARGE:** Connect the charge alternator's D+ end to this terminal. This terminal will supply the excitation current and measure the voltage of the charge alternator.

### OUTPUTS

**FUEL SOLENOID** : 10amps@28V-DC.

**START** : 10amps@28V-DC.

**AUXILIARY** : 10amps@28V-DC.

### OPTIONS

#### JUMPER SELECTABLE STANDARD FEATURES:

Genset control,  
Activate to Start,  
Energize to Stop,  
50Hz nominal,  
60Hz nominal.

#### OPTIONAL FEATURES:

**(SUBJECT TO SPECIAL ORDER)**

Engine control (without alternator),  
Remote start input (DKG-152),  
Negative pulling semiconductor outputs (DKG-153).

### TECHNICAL SPECIFICATIONS

**Alternator Voltage:** 15 to 300 V-AC

**Alternator Frequency:** 50 or 60 Hz nominal.

**Overspeed:** nominal frequency + 14%  
(+ 24% overshoot)

**Underspeed:** 25Hz

**DC Supply Range:** 8 to 33 V-DC.

**Current consumption:** 80mA max. (Relay outputs open).

**Charge fail threshold:** 6 V-DC.

**Charge excitation current:** via 82 ohms resistor connected to the FUEL output.

**Stop Timeout:** 30 sec.

**Operating temp.:** -20°C (-4°F) to 70 °C (158°F).

**Storage temp.:** -30°C (-22°F) to 80 °C (176°F).

**Maximum humidity:** 95% non-condensing.

**Dimensions:** 72x72x38mm (WxHxD)

**Panel cutout dimensions:** 68x68 mm

**Weight:** 140g (approx.)

**Installation:** Front panel mounted. Retaining steel spring provided.

#### DATAKOM Electronics Limited

Tel : +90-216-466 84 60

Fax : +90-216-364 65 65

e-mail : [datakom@datakom.com.tr](mailto:datakom@datakom.com.tr)

http: [www.datakom.com.tr](http://www.datakom.com.tr)