

DKG-517-J MANUAL AND REMOTE START UNIT WITH J1939 INTERFACE

DESCRIPTION

The DKG-517-J is a comprehensive generator control unit designed to start and stop the generating set both manually and remotely. The manual control is made using the pushbuttons on the front panel. The remote control is made via the **REMOTE START** input signal.

The unit can connect to ECU controlled electronic engines through its standard J1939 CANBUS port providing engine control, protection and instrumentation without extra senders. The ECU alarms are displayed with SPN-FMI codes.

In **RUN** position, the unit controls the automatic starting and stopping of the generating set. Once the generator is running, it monitors internal protections and external fault inputs. If a fault condition occurs, the unit shuts down the engine automatically and indicates the failure source with the corresponding red led lamp.

The operation of the unit is controlled with front panel pushbuttons. The **RUN** and **STOP** pushbuttons select the operating mode. If the **STOP** button is pressed or the **REMOTE START** signal is removed, the engine will be stopped. Other buttons select the display parameter scroll, alarm mute and lamp test functions.

The unit provides a comprehensive set of digitally adjustable timers, threshold levels, input and output configurations, operating sequences and engine types. The unauthorized access to program parameters is prevented by the program lock input. All programs may be modified via front panel pushbuttons, and do not require an external unit.

The fault conditions are considered in 2 categories as Warnings and Alarms. Measured values have separate programmable limits for warning and alarm conditions. The unit is able to initiate modem calls and sending SMS messages in fault conditions.

The service request indicator lamp turns on at the expiration of either engine hours or time limits.

It is possible to monitor and control the operation of the system locally or remotely with the WINDOWS based RAINBOW program.

The unit supports MODBUS protocol enabling communication with PLCs and building management systems. The MODBUS protocol is also supported through GSM and PSTN modems.

The unit is designed for front panel mounting. Connections are made with 2 part plug and socket connectors.

MEASUREMENTS

Generator Volts: U-N, V-N, W-N
 Generator Volts: U-V, V-W, W-U
 Generator Amps: U, V, W
 Generator total KW
 Generator pf
 Generator Frequency,
 Engine rpm
 Battery Voltage
 Engine Coolant Temperature
 Engine Oil Pressure
 Fuel Level

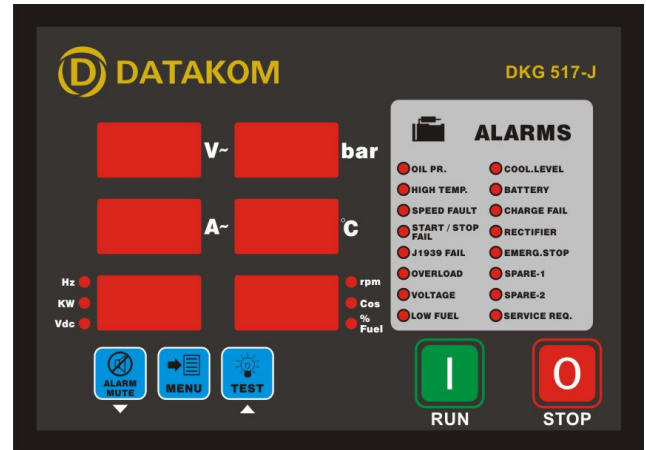

FEATURES

- Both manual and remote starting and stopping ECU control and monitoring through J1939 CAN**
- Various engine brands and models available**
- Engine control**
- Generator protection**
- Built in alarms and warnings**
- Remote Start operation available**
- Periodic maintenance request indicator**
- Event logging with time stamp**
- Statistical counters**
- Battery backed-up real time clock**
- Operation password capability**
- Provision for dual genset operation**
- Fuel pump control**
- Block heater control**
- Field adjustable parameters**
- RS-232 serial port**
- Free MS-Windows Remote monitoring SW:**
 - local, LAN, IP and modem connection
 - monitoring, download of parameters
 - modem networking
- GSM and PSTN modem support**
- GSM SMS message sending on fault**
- MODBUS communications**
- LED displays**
- Configurable analogue inputs: 2**
- Configurable digital inputs: 7**
- Configurable relay outputs: 2**
- Total relay outputs: 4**
- I/O expansion capability**
- Survives cranking dropouts**
- Sealed front panel**
- Plug-in connection system for easy replacement**

STATISTICS

Following incremental counters provide statistics about past performance of the generating set:

- Engine Hours Run
- Engine Hours to Service
- Time to Service
- Number of Engine Cranks
- Number of Genset Runs

EVENT LOGGING

The unit records last 32 events with date and time stamp. Recorded events are:

- alarms and warnings
- generator run / stop information

DIGITAL INPUTS

The unit has 7 configurable digital inputs. Each input has following programmable parameters:

- alarm type: shutdown / warning / no alarm
- alarm polling: on engine running / always
- latching / non-latching operation,
- contact type: NO / NC
- switching: BAT+ / BAT-

ANALOG INPUTS

Engine analog inputs are provided for the coolant temperature, oil pressure and fuel level. Analog inputs connect to resistive sender units to provide precise and adjustable protection. The coolant temperature and oil pressure inputs have programmable sensor characteristics so that they are suitable for any type and any brand of sensors.

RELAY OUTPUTS

The unit provides 4 relay outputs and 2 of them have programmable functions, selectable from a list. Any function or alarm condition may be output as a relay contact. Using two Relay Expansion Modules, the number of relays may be increased up to 20, 16 of them being volt-free contacts.

TELEMETRY AND REMOTE PROGRAMMING

The unit provides the user with large telemetry facilities via its standard RS-232 serial port, connecting either to a PC, PLC or a GSM or PSTN modem. It supports both RAINBOW and MODBUS communication protocols. The standard PC software offers local, Local Area Network (LAN), internet and modem operation capabilities as well as modem networking feature. The PC program is used for below purposes:

- parameter upload/download
- remote monitoring and control
- diagnostics and analysis

The MODBUS interface allows the unit to be integrated in building management systems.

TECHNICAL SPECIFICATIONS

Alternator voltage: 0 to 300 V-AC (Ph-N)

Alternator frequency: 0-100 Hz.

DC Supply Range: 9.0 to 30.0 V-DC

Cranking dropouts: survives 0 V for 100ms.

Typical Standby Current: 150 mA-DC

Maximum Operating Current: 450 mA-DC (Relay outputs open)

Generator Contactor Relay Output: 16 A / 250V

DC Relay Outputs: 10 A / 28V

Charge excitation current: min 150mA @ 10 to 30 V-DC.

Current inputs: from CTs, .../5A. Max load 0.7VA per phase.

Analog input range: 0-5000 ohms.

Serial port: RS-232, 9600 bauds, no parity, 1 bit stop

Operating temp.: -20°C (-4°F) to 70 °C (158°F).

Storage temp.: -40°C (-40°F) to 80 °C (176°F).

Dimensions: 190 x 135 x 48 mm (WxHxD)

Panel Cut-out Dimensions: 176x121 mm minimum.

Weight: 430 g (approx.)

Case Material: High Temperature ABS (UL94-V0, 100°C)

IP Protection: IP65 from front panel, IP30 from the rear.

Conformity (EU directives)

-2006/95/EC (low voltage)

-2004/108/EC (electro-magnetic compatibility)

Norms of reference:

EN 61010 (safety requirements)

EN 61326 (EMC requirements)

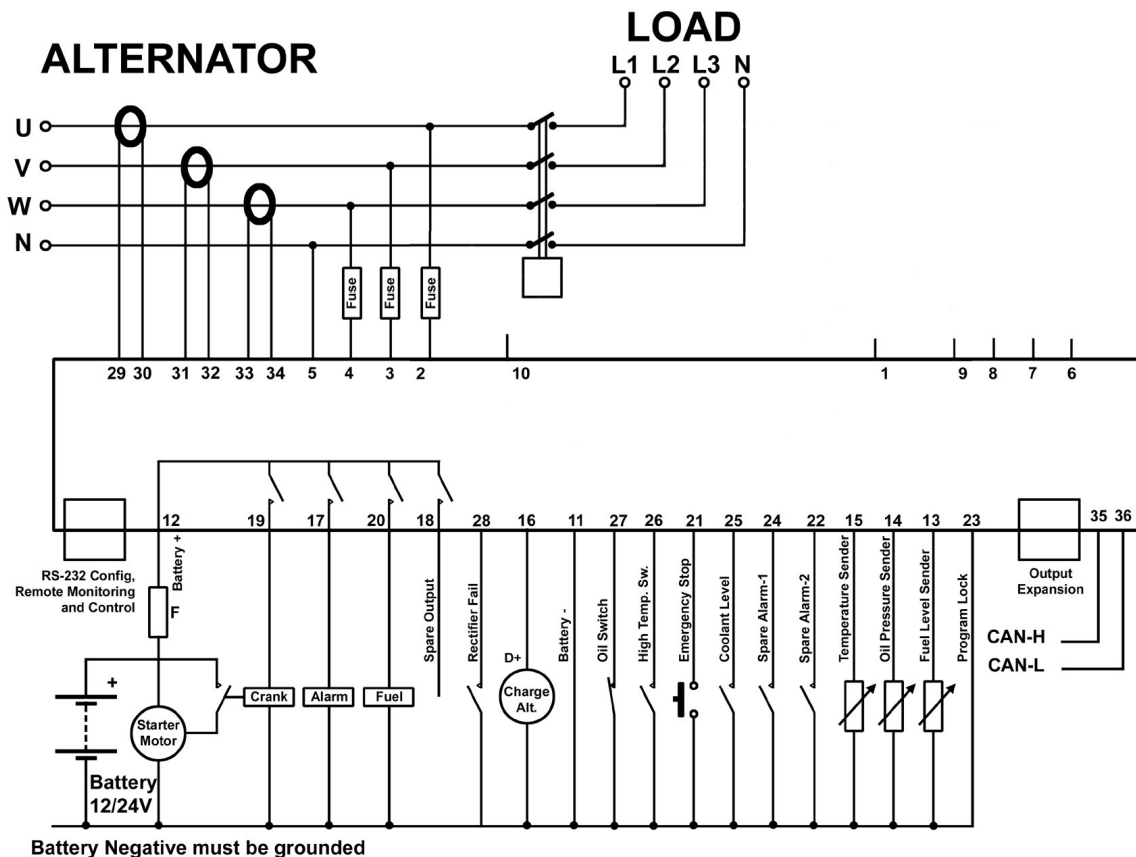

DATAKOM Electronics Ltd.

Tel : +90-216-466 84 60

Fax : +90-216-364 65 65

http: www.datakom.com.tr

e-mail : datakom@datakom.com.tr