

**DVF-0303 VOLT-FREQUENCY METER**  
**72x72mm**  
**TRUE RMS**

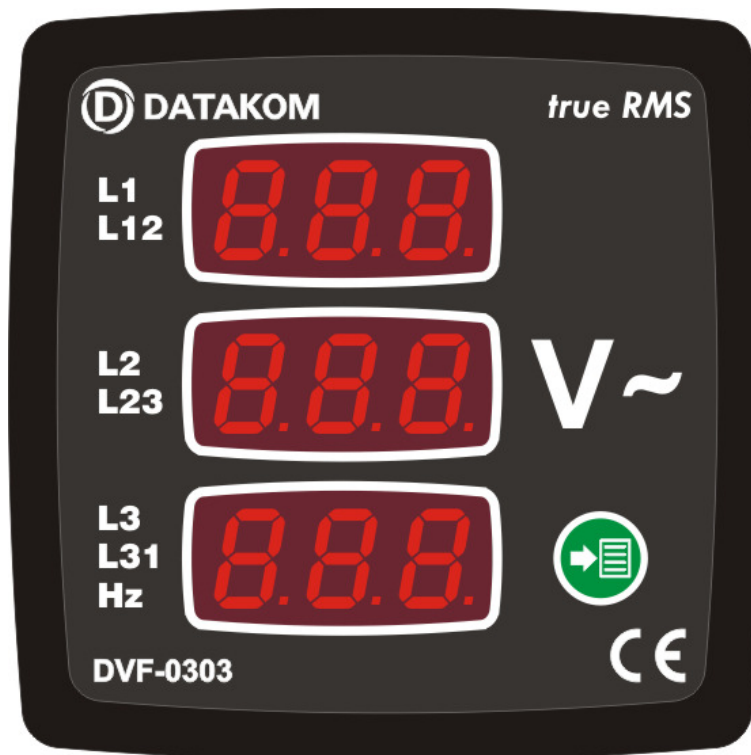

## INTRODUCTION

These state-of-the-art panel meters are designed for accurate measurement of the AC RMS voltages and frequency in three-phase systems.

Although they are mainly used in electrical panels, these devices can also be integrated in many other applications.

Devices have separate inputs for supply and measurement with common neutral point.

Through front panel buttons, phase-to-phase (L1-L2, L2-L3, L3-L1) and phase-to-neutral (L1-N, L2-N, L3-N) voltages and frequency can be selected and read from the display. Automatic parameter scroll is also available

## CONNECTION DIAGRAMS

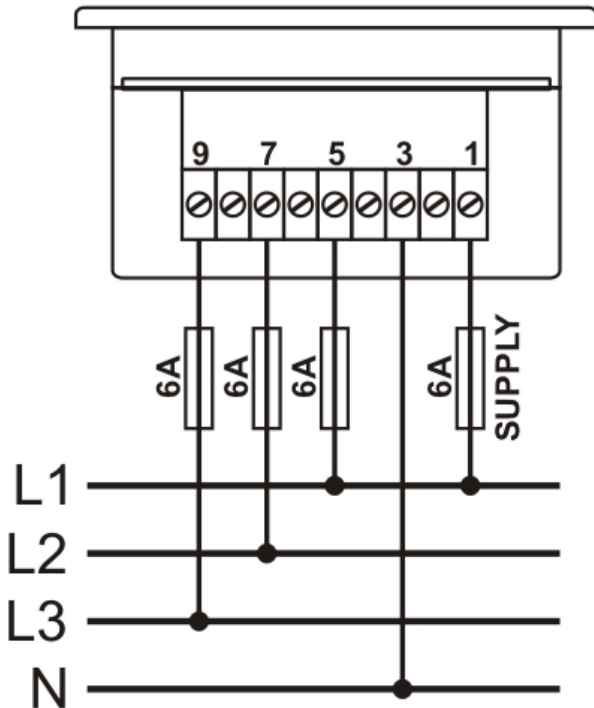

## PANEL CUTOUT DIMENSIONS

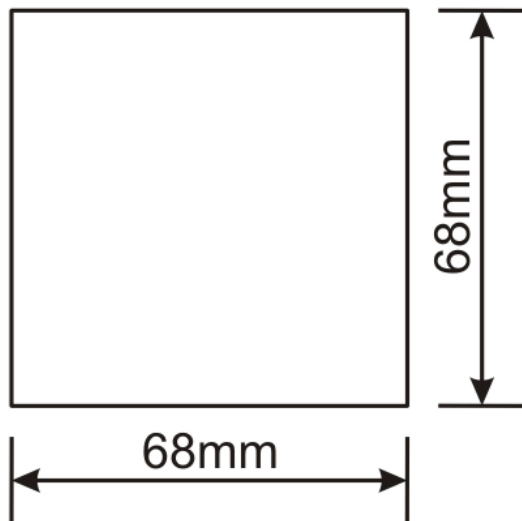

## MOUNTING TOLERANCES

WALL

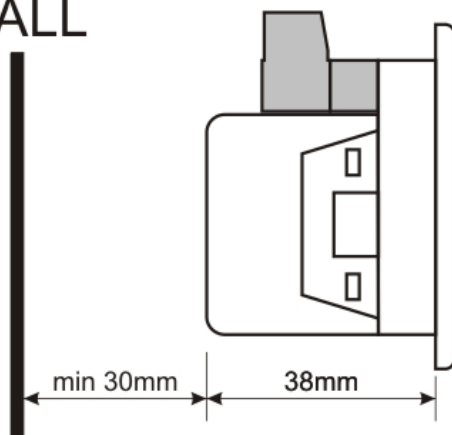

## TECHNICAL SPECIFICATIONS

**Power Supply Input:** 170 - 275VAC  
50 - 60Hz nominal ( $\pm 10\%$ )  
Different AC/DC supply values available.

**Measurement Inputs:**  
10 - 300 V AC (Phase-Neutral)  
20 - 520 V AC (Phase-Phase)  
30 - 100 Hz

**Accuracy:** 0.5% + 1 digit

**Power Consumption:** < 1.5W

**Burden:** < 0.1VA per phase

**Operating Temperature:** -40°C ; +80 °C

**Maximum Humidity:** 95% non-condensing.

**Degree of Protection:** IP 54 (Front Panel)  
IP 30 (Back panel)

**Enclosure:**  
Non-flammable, ROHS compliant, high temperature ABS/PC (UL94-V0)

**Installation:**  
Flush mounting with rear retaining brackets

**Dimensions:** 78x78x41mm (WxHxD)

**Panel Cutout Dimensions:** 68x68mm

**Weight:** 145 gr

**EU Directives Conformity:**  
2006/95/EC (low voltage)  
2004/108/EC (EMC)

**Norms of reference:**  
EN 61010 (safety requirements)  
EN 61326 (EMC requirements)

## PACKAGING INFORMATION

**Pieces per Package:** 24 Pcs

**Package Size:** 280 x 170 x 215mm (LxWxH)

**Package Weight:** 3.7 kg

**DATAKOM Electronics Limited**

Tel : +90-216-466 84 60

Fax : +90-216-364 65 65

e-mail : [datakom@datakom.com.tr](mailto:datakom@datakom.com.tr)

http: [www.datakom.com.tr](http://www.datakom.com.tr)

